

Cavalok Building Products Ltd

Black Barn
Mythe Business Centre
Tewkesbury
Gloucestershire GL20 6EA

Tel: 0870 120 3003 Fax: 0870 121 3003

e-mail: sales@cavalok.com

website: www.cavalok.com



Agrément Certificate

00/3673

Product Sheet 1

CAVALOK CAVITY CLOSER SYSTEMS

CAVALOK CAVITY CLOSER AND FRAME ACCEPTOR SYSTEM

This Agrément Certificate Product Sheet⁽¹⁾ relates to the Cavalok Cavity Closer and Frame Acceptor System, for use as a cavity closer and to form an opening in masonry cavity walls and timber-framed and steel-framed buildings during construction. The system can also provide ventilation via the vented head section.

(1) Hereinafter referred to as 'Certificate'.

CERTIFICATION INCLUDES:

- factors relating to compliance with Building Regulations where applicable
- factors relating to additional non-regulatory information where applicable
- independently verified technical specification
- assessment criteria and technical investigations
- design considerations
- installation guidance
- regular surveillance of production
- formal three-yearly review.

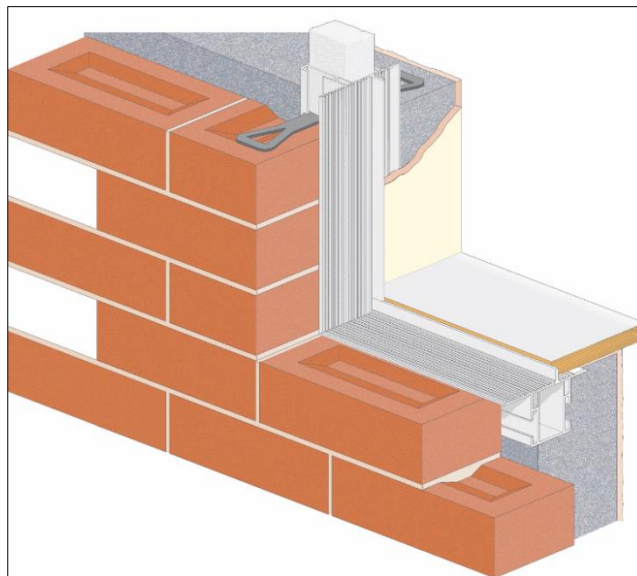

KEY FACTORS ASSESSED

Hygrothermal behaviour — the cavity closers meet and exceed the minimum thermal resistance path of $0.45 \text{ m}^2 \cdot \text{K} \cdot \text{W}^{-1}$ as required by the Accredited Construction Details. Default ψ values (psi) in BRE Information Paper IP 1/06 may, therefore, be used for jamb and sill junctions in SAP or SBEM calculations (see section 6).

Water resistance — the system is effective as a damp-proof barrier and, when used in a suitable wall construction, will resist the passage of water into the interior of the building in flush and check reveal installations (see section 7).

Structural stability — in terms of wind loading resistance, the system can be used in all areas of the UK. The system must not be used to support loads from the masonry (see section 8).

Properties in relation to fire — the installed system will not contribute significantly to the growth of a fire. The system does not constitute a cavity barrier (see section 9).

Durability — the cavity closer profiles, protected within the cavity, will continue to function for the normal expected life of a building; visible components will have an expected life in excess of 35 years (see section 11).

The BBA has awarded this Certificate to the company named above for the system described herein. This system has been assessed by the BBA as being fit for its intended use provided it is installed, used and maintained as set out in this Certificate.

On behalf of the British Board of Agrément

Date of Sixth issue: 15 May 2019

John Albon
Chief Scientific Officer

Originally certificated on 24 March 2000

Claire Curtis-Thomas
Chief Executive

The BBA is a UKAS accredited certification body – Number 113.

The schedule of the current scope of accreditation for product certification is available in pdf format via the UKAS link on the BBA website at www.bbacerts.co.uk
Readers are advised to check the validity and latest issue number of this Agrément Certificate by either referring to the BBA website or contacting the BBA direct.

Any photographs are for illustrative purposes only, do not constitute advice and should not be relied upon.

British Board of Agrément

Bucknalls Lane
Watford
Herts WD25 9BA

©2019

Page 1 of 14

tel: 01923 665300
clientservices@bbacerts.co.uk
www.bbacerts.co.uk



Regulations

In the opinion of the BBA, the Cavalok Cavity Closer and Frame Acceptor System, if installed, used and maintained in accordance with this Certificate, can satisfy or contribute to satisfying the relevant requirements of the following Building Regulations (the presence of a UK map indicates that the subject is related to the Building Regulations in the region or regions of the UK depicted):



The Building Regulations 2010 (England and Wales) (as amended)

Requirement:	C2(b)	Resistance to moisture
Comment:		The system has adequate resistance to the ingress of rain and wind-driven spray and so can contribute towards the wall satisfying this Requirement. See section 7 of this Certificate.
Requirement:	C2(c)	Resistance to moisture
Comment:		The system will not constitute a significant condensation risk and so can contribute towards the wall satisfying this Requirement. See sections 6.2 and 6.3 of this Certificate.
Requirement:	L1(a)(i)	Conservation of fuel and power
Comment:		The system can contribute to minimising heat loss at jambs and sills. See section 6.1 of this Certificate.
Regulation:	7	Materials and workmanship (applicable to Wales only)
Regulation:	7(1)	Materials and workmanship (applicable to England only)
Comment:		The system is acceptable. See section 11 and the <i>Installation</i> part of this Certificate.
Regulation:	26	CO₂ emission rates for new buildings
Regulation:	26A	Fabric energy efficiency rates for new dwellings (applicable to England only)
Regulation:	26A	Primary energy consumption rates for new buildings (applicable to Wales only)
Regulation:	26B	Fabric performance values for new dwellings (applicable to Wales only)
Comment:		The system can contribute to minimising heat loss at jambs and sills. See sections 6.1 and 6.2 of this Certificate.



The Building (Scotland) Regulations 2004 (as amended)

Regulation:	8(1)	Durability, workmanship and fitness of materials
Comment:		The system can contribute to a construction satisfying this Regulation. See section 11 and the <i>Installation</i> part of this Certificate.
Regulation:	9	Building standards applicable to construction
Standard:	3.10	Precipitation
Comment:		The system has adequate resistance to the ingress of rain and wind-driven spray and so can contribute towards the wall satisfying this Standard, with reference to clauses 3.10.1 ⁽¹⁾⁽²⁾ and 3.10.3 ⁽¹⁾⁽²⁾ . See section 7 of this Certificate.
Standard:	3.15	Condensation
Comment:		The system will not constitute a significant condensation risk and so can contribute towards the wall satisfying this Standard, with reference to clauses 3.15.1 ⁽¹⁾⁽²⁾ , 3.15.4 ⁽¹⁾⁽²⁾ and 3.15.5 ⁽¹⁾⁽²⁾ . See sections 6.2 and 6.3 of this Certificate.
Standard:	6.1(b)	Carbon dioxide emissions
Standard:	6.2	Building insulation envelope
Comment:		The system can contribute to minimising heat loss at jambs and sills, with reference to clauses 6.2.3 ⁽¹⁾⁽²⁾ , 6.2.4 ⁽¹⁾⁽²⁾ and 6.2.5 ⁽²⁾ . See section 6.1 of this Certificate.

Standard: 7.1(a)(b) **Statement of sustainability**
Comment: The system can contribute to meeting the relevant requirements of Regulation 9, Standards 1 to 6, and therefore will contribute to a construction meeting a bronze level of sustainability as defined in this Standard. In addition, the system can contribute to a construction meeting a higher level of sustainability as defined in this Standard, with reference to clauses 7.1.4⁽¹⁾⁽²⁾ [Aspects 1⁽¹⁾⁽²⁾ and 2⁽¹⁾], 7.1.6⁽¹⁾⁽²⁾ [Aspects 1⁽¹⁾⁽²⁾ and 2⁽¹⁾] and 7.1.7⁽¹⁾⁽²⁾ [Aspect 1⁽¹⁾⁽²⁾]. See section 6 of this Certificate.

Regulation: 12 **Building standards applicable to conversions**
Comment: Comments in relation to the system under Regulation 9, Standards 1 to 6, also apply to this Regulation, with reference to clause 0.12.1⁽¹⁾⁽²⁾ and Schedule 6⁽¹⁾⁽²⁾.

(1) Technical Handbook (Domestic)
(2) Technical Handbook (Non-Domestic).



The Building Regulations (Northern Ireland) 2012 (as amended)

Regulation: 23 **Fitness of materials and workmanship**
Comment: The system is acceptable. See section 11 and the *Installation* part of this Certificate.

Regulation: 28 **Resistance to moisture and weather**
Comment: The system has adequate resistance to the ingress of rain and wind-driven spray and so can contribute towards the wall satisfying this Regulation. See section 7 of this Certificate.

Regulation: 29 **Condensation**
Comment: The system will not constitute a significant condensation risk and so can contribute towards the wall satisfying this Regulation. See section 6.3 of this Certificate.

Regulation: 39(a)(i) **Conservation measures**
Regulation: 40(2) **Target carbon dioxide emission rate**
Comment: The system can contribute to minimising heat loss at jambs and sills. See sections 6.1 and 6.3 of this Certificate.

Construction (Design and Management) Regulations 2015

Construction (Design and Management) Regulations (Northern Ireland) 2016

In the opinion of the BBA, there is no information in this Certificate which relates to the obligations of the client, designer (including Principal Designer) and contractor (including Principal Contractor) under these Regulations.

Additional Information

NHBC Standards 2019

In the opinion of the BBA, the Cavalok Cavity Closer and Frame Acceptor System, if installed, used and maintained in accordance with this Certificate, can satisfy or contribute to satisfying the relevant requirements in relation to *NHBC Standards*, Chapter 6.1 *External masonry walls*.

Technical Specification

1 Description

1.1 The Cavalok Cavity Closer and Frame Acceptor System (see Figure 1) is an insulated, unplasticised polyvinyl chloride (PVC-U) cavity closer, used to form an opening in masonry cavity walls during construction. The PVC-U sections of the frame are box profiled sections, enclosing closed-cell, expanded polystyrene (EPS) core insulation. 90 mm and 100 mm closers are fitted with an extruded polystyrene (XPS) add-on insulation. The profiles are formed as a three-sided, U-shaped, PVC-U frame temporarily braced with a PVC-U brace system (see Figure 1) or a timber brace (see Figure 2).

The head bracings must be removed prior to the installation of the window/door frames. Alternatively, a vented head profile is mechanically joined to form the head section. For some applications, a frame composed of four sides of cavity closer profile may be produced, eg to close the cavity at the head where lintels are separated.

Figure 1 Closer frame with PVC-U brace



Figure 2 Closer frame with timber brace



1.2 PVC-U sections are available to suit 50 mm, 75 mm, 90 mm and 100 mm wide cavities (see Figure 3).

1.3 The cavity closer components and accessories are shown in Figure 3.

1.4 The main PVC-U profile incorporates a box section to fit into the recess of the wall cavity.

Figure 3 Components



flat top closer
50 mm and 75 mm



internal fit closer
50 mm and 75 mm



external fit closer
50 mm and 75 mm



check reveal closer
50 mm and 75 mm



flat top closer
90 mm and 100 mm



check reveal closer
90 mm and 100 mm

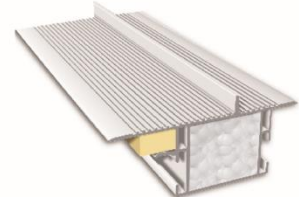

external fit closer
90 mm and 100 mm

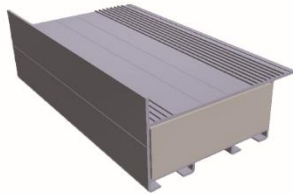

DM100CHK 100 mm closer

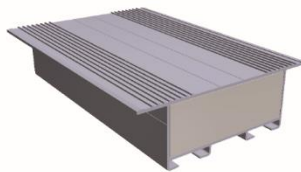

DN100HOR 100 mm closer

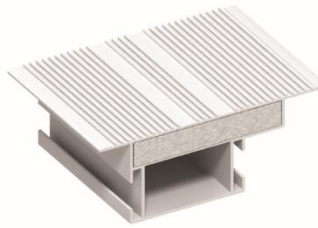

I100HORCBX 100 mm closer



wall tie



flat cleat



frame hangers 50 mm,
75 mm and 100 mm



stainless steel locking clip



brace bar

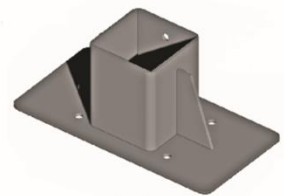

brace boot



corners 50 mm and 75 mm



corners 100 mm



vented head



vented head end cap

1.5 Proprietary injection-moulded polypropylene brick ties and stainless steel clips are available from the Certificate holder for fixing the frame into the surrounding masonry and for securing the frame to the closer when using an upstand variant, respectively (see Figures 3 and 4).

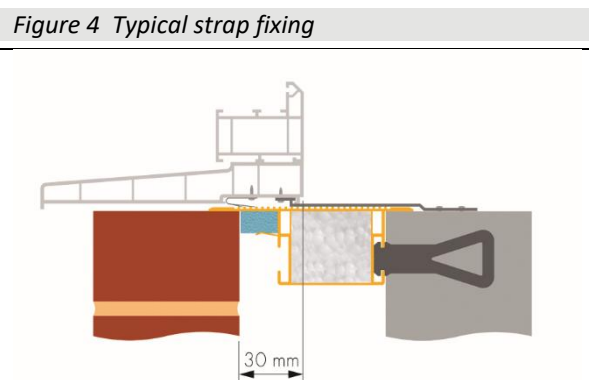

2 Manufacture

2.1 The cavity closer unplasticised polyvinyl chloride (PVC-U) profiles are produced by conventional extrusion techniques. The insulation is fitted in the factory.

2.2 As part of the assessment and ongoing surveillance of product quality, the BBA has:

- agreed with the manufacturer the quality control procedures and product testing to be undertaken
- assessed and agreed the quality control operated over batches of incoming materials
- monitored the production process and verified that it is in accordance with the documented process
- evaluated the process for management of nonconformities
- checked that equipment has been properly tested and calibrated
- undertaken to carry out the above measures on a regular basis through a surveillance process, to verify that the specifications and quality control being operated by the manufacturer are being maintained.

3 Delivery and site handling

3.1 Closer sections are transported in self-supporting shrink-wrapped bundles. Ancillary items are dispatched in bags or boxes. The packs bear component identification, a manufacturing reference, date of production and the BBA logo incorporating the number of this Certificate.

3.2 Assembled sub-frames are stacked vertically and delivered to site as individual items from the fabricator with the fixing ties in bags. Care must be taken to avoid distortion in transit.

3.3 The sub-frames and packs of cavity closer profiles should be stored under cover in a clean area (on edge in the case of sub-frames) away from direct sunlight and excessive heat and protected from vehicular and pedestrian traffic, and supported along their length to avoid distortion or damage.

Assessment and Technical Investigations

The following is a summary of the assessment and technical investigations carried out on the Cavalok Cavity Closer and Frame Acceptor System.

4 General

4.1 The Cavalok Cavity Closer and Frame Acceptor System is suitable for use in masonry walls with nominal cavity widths of 50 mm, 75 mm, 90 mm and 100 mm, for fixing PVC-U, timber, aluminium, steel and composite window and door frames. It can also be used in timber-framed and steel-framed buildings.

4.2 The system can be used as a template, to form an opening around which a wall can be constructed and to establish the cavity width during construction.

4.3 The system provides a damp-proof barrier between inner and outer wall leaves at the point of closure, acts as a cavity closer without forming a thermal bridge and avoids the need for cutting bricks and blocks. The window/door is fitted after completion of the masonry. It can also be used to form a check reveal where required and to fit the window or door after completion of the masonry, as is conventional practice in Scotland and Northern Ireland.

4.4 Trickle ventilators⁽¹⁾ can be fitted to the vented head section.

(1) Outside the scope of this Certificate.

4.5 Masonry walls into which the system is incorporated must be constructed in accordance with the national Building Regulations and one or more of the following technical specifications:

- BS 8000-0 : 2014
- BS 8000-3 : 2001
- BS EN 1996-1-1 : 2005 and its UK National Annex
- BS EN 1996-1-2 : 2005 and its UK National Annex
- BS EN 1996-2 : 2006 and its UK National Annex
- PD 6697: 2010.

4.6 Timber stud walls should be designed and constructed in accordance with the national Building Regulations and BS EN 1995-1-1 : 2004 and its UK National Annex. Studding and framing should be adequately supported by noggings to ensure rigidity.

4.7 New steel-framed walls must be constructed in accordance with the national Building Regulations and the relevant recommendations of:

- BS EN 1993-1-1 : 2005 and its UK National Annex
- BS 8000-0 : 2014
- BS EN 10346 : 2015.

4.8 Sections for use at the jamb and for externally installed windows at the sill have an upstand against which the window/door frame is positioned.

4.9 Alternatively, when using a variant without an upstand, the window should be positioned a minimum of 30 mm over the cavity and fixed to the inner structure using a proprietary strap fixing⁽¹⁾ (see Figure 4).

(1) Outside the scope of this Certificate.

5 Practicability of installation

The system is designed to be installed by a competent general builder, or a contractor, experienced with this type of system.

6 Hygrothermal behaviour



6.1 The system can contribute to maintaining continuity of thermal insulation at jambs and sills in wall openings. The path of minimum thermal resistance through the closers calculated to BRE Information Paper IP 8/08 is at least $0.45 \text{ m}^2 \cdot \text{K} \cdot \text{W}^{-1}$ when used in jambs and sills with the window/door frame set back

30 mm or more into the wall cavity (see Figure 5). Example junction details shown in Figure 5 are acceptable. For Accredited Construction Details, the corresponding ψ values (psi) in BRE Information Paper IP 1/06 Table 3 may be used in carbon emission calculations in Scotland and Northern Ireland. Attention must be given to the correct setback in order to ensure compliance with these requirements. Detailed guidance on limiting heat loss and air filtration can be found in the documents supporting the national Building Regulations.



6.2 Jambs and sills incorporating the system, in accordance with section 6.1 of this Certificate, will adequately limit the risk of local surface condensation.



6.3 Under normal domestic conditions, the level of interstitial condensation associated with the system will be low and the risk of any resultant damage minimal.

6.4 Door frames installed with proprietary fixings which cannot be set back into the wall cavity by 30 mm (see section 6.1) may require additional thermal insulation, for example: insulated dry lining, to minimise excessive heat loss and the risk of excessive surface condensation.

6.5 The junctions between the wall and the front and back of the window/door frame must be effectively sealed.

7 Water resistance



7.1 The system is effective as a vertical damp-proof barrier at jambs of window and door openings in masonry constructions where a brick/block closer and damp-proof course (dpc) detail would normally be used. The closers are also effective as a horizontal damp-proof barrier at the sill or threshold.

7.2 Installations with a flush (in-line) wall opening with a minimum window setback of 30 mm (see section 6.1 and Figure 5 of this Certificate) are suitable for use in the exposure zones 1 'sheltered'⁽¹⁾, 2 'moderate'⁽¹⁾ and 3 'severe'⁽¹⁾. The closers may also be considered suitable for use in other areas where a conventional return brick/block closer detail with dpc has been found to provide adequate resistance to the penetration of wind-driven rain.

7.3 The system may also be used to construct a check reveal (see Figure 5). In this construction, in which the frame is positioned in a rebate behind the outer leaf of the jamb, the system is suitable for use in exposure zones up to and including zone 4 'very severe'⁽¹⁾⁽²⁾. However, a dpc may be fitted between the closer and outer leaf if required.

(1) As depicted in the map in Section 3.1 of BRE Report BR 262 : 2002.

(2) This covers all exposure zones in the United Kingdom.

8 Structural stability

8.1 The system is non-loadbearing and must not be used to support loads from the masonry. Window and door frames must be fixed independently onto the masonry. Proprietary frame fixings, which may be recommended by the Certificate holder, are not covered by this Certificate. Lintels are required above window or door openings.

8.2 The system will not have an adverse effect on the structural stability of brickwork, blockwork or timber-frame walls constructed in the conventional manner in accordance with normal good practice, as defined in the Standards listed in sections 4.5 and 4.6. Use of the system does not obviate the need for conventional wall ties around the openings.

8.3 PVC-U windows fixed to the closer frame (and, where necessary, to the inner leaf at the sill) with retaining clips, or to the masonry or lintel at the head, or alternatively fixed by a proprietary strap fixing, will satisfactorily transfer to the structure the wind loads likely to be encountered in the UK. It is recommended that window frames are reinforced, particularly those:

- with side members over one metre in length
- used in exposed areas
- with an opening light at the jamb.

8.4 For opening light windows there is a tendency for the frame to distort under the forces exerted by the clips, when the window is opened. This is particularly so for reinforced window frames. To prevent this distortion, additional screw fixing of the frame to the closer is recommended, as detailed in the *Cavalok Technical Fabrication Manual*.

9 Properties in relation to fire

9.1 The installed system will not contribute significantly to the growth of a fire.

9.2 The system does not constitute a cavity barrier against the penetration of smoke and flame; therefore, it should be used in conjunction with cavity barriers located and satisfying the performance requirements defined in the documents supporting the national Building Regulations.

9.3 The use of the system does not preclude the need to provide suitable fire protection to steel lintels where this is necessary to satisfy the requirements of the national Building Regulations.

10 Maintenance

To ensure the maximum weathertightness, the silicone seal between window or door frames and masonry must be checked regularly and repairs or renewal carried out promptly.

11 Durability



The system is durable when installed in accordance with this Certificate and will not suffer significant degradation when protected within the cavity. The system will continue to function for the normal expected life of a building. Visible components will have an expected life in excess of 35 years.

12 Reuse and recyclability

The PVC-U profiles of the system can be recycled.

Installation

13 General

13.1 Installation of the Cavalok Cavity Closer and Frame Acceptor System must be carried out in accordance with the Certificate holder's instructions.

13.2 A cavity barrier may be required (see section 9.2 of this Certificate).

13.3 The appropriate closer is selected for the job (see Figure 3).

13.4 Reference should be made to the typical installation details shown in Figure 5 when reading the installation details given in section 14. Care must be taken to ensure that when the 50 mm closer is used in externally installed applications, it is positioned correctly, such that the window/door frames are set back by at least 30 mm over the cavity. The windows in Figure 5 are shown for information only and do not form part of this assessment.

13.5 In cutting the components to length, care should be taken to achieve clean, flat, square ends.

13.6 Window/door frames must be set back at least 30 mm behind the outer leaf, and the junctions between the wall and the front and back of the window/door frame and sill effectively sealed (see section 6.1 of this Certificate).

Figure 5 Installation details

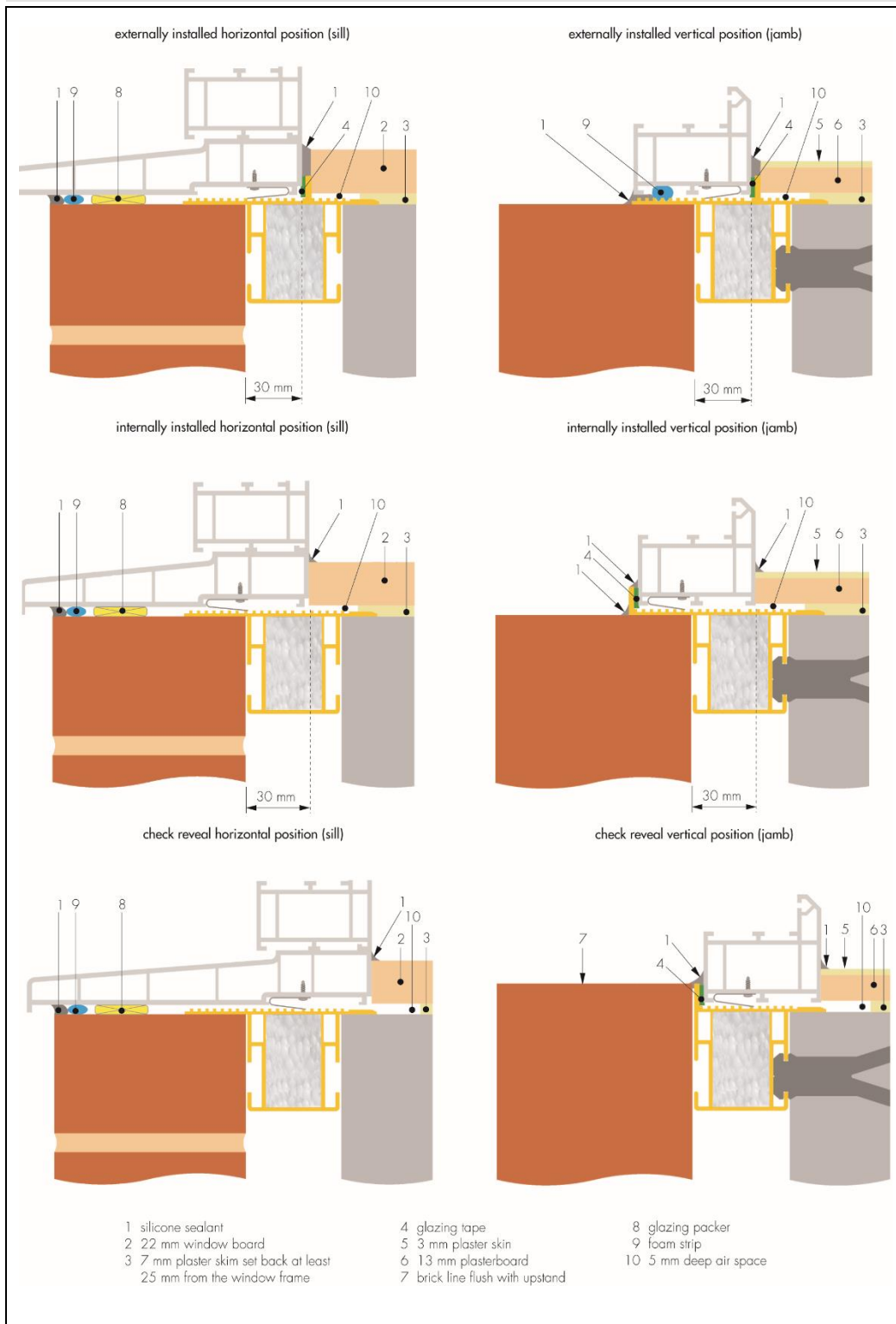

14 Procedure

14.1 The wall is built to sill/threshold level.

14.2 The preformed cavity closer frame is placed into the cavity at the sill at the intended position of the opening. It must be ensured that the cavity frame remains plumb, level, square and with parallel sides.

14.3 The frame should be a tight fit in the cavity at the sill/threshold. If not, it is recommended that, after installation, the closer frame or window frame is fixed back to the inner leaf at the sill with a rigid strap fixing or equivalent, particularly for installations involving larger windows (above one metre wide) and/or in exposed conditions.

14.4 Masonry is built up around the closer to lintel height, and the closer frame fixed to it with brick ties. The brick ties are fitted into the closer channel and embedded in the mortar joints of both the outer brick leaf (every sixth course) and the inner block leaf (every other course).

14.5 When the mortar has set, the timber or PVC-U bracing is removed from the closer frame and the lintel positioned at the head, ensuring that it is supported only by the masonry, ie the closer must not bear any weight. If a four-sided closer frame is being installed, the split lintel should be positioned on either side of the closer frame and further consideration made to the dpc requirements at the head.

14.6 It is recommended that the closer is sealed to the wall using an appropriate sealant or sealing tape to help meet airtightness regulations.

14.7 The closer is then ready to accept the window/door.

PVC-U windows

14.8 Stainless steel locking clips can be fitted to the window frame (see Figure 6) or, alternatively, fixing straps can be used.

Figure 6 Window with locking clips



14.9 The window frame is pushed centrally into the opening, ensuring that it locates against the closer stop at jamb and sill and that all locking clips engage.

14.10 The head of the window frame is fixed back to the masonry or lintel.

14.11 Where necessary, the window frame is fixed back to the inner leaf at the sill (see section 14.3 of this Certificate).

14.12 A silicone sealant is applied at appropriate positions around the window frame (see Figure 5).

PVC-U, aluminium, timber and steel windows

14.13 Strap fixings should be fixed to the underside of the window profile and fixed back with screws onto the structural opening.

14.14 For timber-frame construction, strapping is fixed back to the wood internal structural opening.

14.15 For brickwork/blockwork construction, strapping is fixed back to the internal blockwork.

14.16 For steel-frame construction, strapping is fixed back to the internal steel opening.

Technical Investigations

15 Tests

15.1 Tests were carried out on the PVC-U extrusions to determine:

- shrinkage on heating
- tensile impact, before and after heat ageing.

15.2 Tests were carried out on a combined closer and PVC-U window installed in a test rig to determine:

- air permeability
- effect of cyclic wind loads
- effect of temperature variation on resistance to wind loading
- safety test, wind loading using increased and reduced pressure of 3000 Pa
- resistance to wind gusting.

16 Investigations

16.1 An assessment was made of:

- heat loss and condensation risk
- weather resistance
- the practicability of the installation
- fire resistance and structural stability of walls incorporating the system
- durability of the components used in the construction of the system.

16.2 The manufacturing process was evaluated, including methods of quality control, and details were obtained of the quality and composition of the materials used.

Bibliography

BRE Information Paper IP 1/06 *Assessing the effects of thermal bridging at junctions and around openings*

BRE Information Paper IP 8/08 *Determining the minimum thermal resistance of cavity closers*

BRE Report BR 262 : 2002 *Thermal insulation: avoiding risks*

BS 8000-0 : 2014 *Workmanship on construction sites — Introduction and general principles*

BS 8000-3 : 2001 *Workmanship on building sites — Code of practice for masonry*

BS EN 1993-1-1 : 2005 + A1 : 2014 *Eurocode 3 : Design of steel structures — General rules and rules for buildings*

NA + A1 : 2014 to BS EN 1993-1-1 : 2005 + A1 : 14 *UK National Annex to Eurocode 3 — Design of steel structures — General rules and rules for buildings*

BS EN 1995-1-1 : 2004 + A2 : 2014 *Eurocode 5 : Design of timber structures — General — Common rules and rules for buildings*

NA to BS EN 1995-1-1 : 2004 + A1 : 2008 *UK National Annex to Eurocode 5 — Design of timber structures — General — Common rules and rules for buildings*

BS EN 1996-1-1 : 2005 + A1 : 2012 *Eurocode 6 : Design of masonry structures — General rules for reinforced and unreinforced masonry structures*

NA to BS EN 1996-1-1 : 2005 + A1 : 2012 *UK National Annex to Eurocode 6 : Design of masonry structures — General rules for reinforced and unreinforced masonry structures*

BS EN 1996-1-2 : 2005 *Eurocode 6 : Design of masonry structures — General rules — Structural fire design*

NA to BS EN 1996-1-2 : 2005 *UK National Annex to Eurocode 6 : Design of masonry structures — General rules — Structural fire design*

BS EN 1996-2 : 2006 *Eurocode 6 : Design of masonry structures — Design considerations, selection of materials and execution of masonry*

NA to BS EN 1996-2 : 2006 *UK National Annex to Eurocode 6 : Design of masonry structures — Design considerations, selection of materials and execution of masonry*

BS EN 10346 : 2015 *Continuously hot-dip coated steel flat products for cold forming — Technical delivery conditions*

PD 6697 : 2010 *Recommendations for the design of masonry structures to BS EN 1996-1-1 and BS EN 1996-2*

17 Conditions

17.1 This Certificate:

- relates only to the product/system that is named and described on the front page
- is issued only to the company, firm, organisation or person named on the front page – no other company, firm, organisation or person may hold or claim that this Certificate has been issued to them
- is valid only within the UK
- has to be read, considered and used as a whole document – it may be misleading and will be incomplete to be selective
- is copyright of the BBA
- is subject to English Law.

17.2 Publications, documents, specifications, legislation, regulations, standards and the like referenced in this Certificate are those that were current and/or deemed relevant by the BBA at the date of issue or reissue of this Certificate.

17.3 This Certificate will remain valid for an unlimited period provided that the product/system and its manufacture and/or fabrication, including all related and relevant parts and processes thereof:

- are maintained at or above the levels which have been assessed and found to be satisfactory by the BBA
- continue to be checked as and when deemed appropriate by the BBA under arrangements that it will determine
- are reviewed by the BBA as and when it considers appropriate.

17.4 The BBA has used due skill, care and diligence in preparing this Certificate, but no warranty is provided.

17.5 In issuing this Certificate the BBA is not responsible and is excluded from any liability to any company, firm, organisation or person, for any matters arising directly or indirectly from:

- the presence or absence of any patent, intellectual property or similar rights subsisting in the product/system or any other product/system
- the right of the Certificate holder to manufacture, supply, install, maintain or market the product/system
- actual installations of the product/system, including their nature, design, methods, performance, workmanship and maintenance
- any works and constructions in which the product/system is installed, including their nature, design, methods, performance, workmanship and maintenance
- any loss or damage, including personal injury, howsoever caused by the product/system, including its manufacture, supply, installation, use, maintenance and removal
- any claims by the manufacturer relating to CE marking.

17.6 Any information relating to the manufacture, supply, installation, use, maintenance and removal of this product/system which is contained or referred to in this Certificate is the minimum required to be met when the product/system is manufactured, supplied, installed, used, maintained and removed. It does not purport in any way to restate the requirements of the Health and Safety at Work etc. Act 1974, or of any other statutory, common law or other duty which may exist at the date of issue or reissue of this Certificate; nor is conformity with such information to be taken as satisfying the requirements of the 1974 Act or of any statutory, common law or other duty of care.